

3300 XL 8 mm Proximity Transducer System

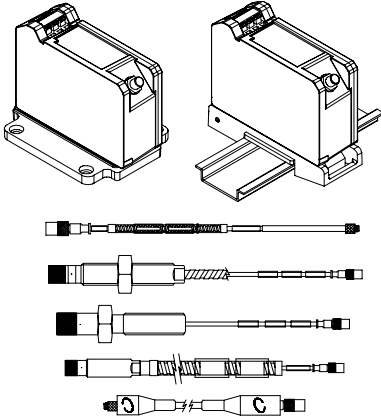

Description

Transducer System

The 3300 XL 8 mm Proximity Transducer System consists of:

- a 3300 XL 8 mm probe
- a 3300 XL extension cable
- a 3300 XL ProximitoR® Sensor¹

The system provides an output voltage directly proportional to the distance between the probe tip and the observed conductive surface. It is capable of both static (position) and dynamic (vibration) measurements, and is primarily used for vibration and position measurement applications on fluid-film bearing machines, as well as Keyphasor® and speed measurement applications².

The 3300 XL 8 mm system represents our most advanced performance in an eddy current proximity transducer system. The standard 3300 XL 8 mm 5 metre system is also 100% compliant with the American Petroleum Institute's (API) 670 Standard (4th Edition) for mechanical configuration, linear range, accuracy, and temperature stability. All 3300 XL 8 mm Proximity Transducer Systems achieve this level of performance while allowing complete interchangeability of probe, extension cable, and ProximitoR® Sensor without the need for individual component matching or bench calibration.

Each component of the 3300 XL 8 mm Transducer System is backward compatible and interchangeable³ with other non-XL 3300 series 5 and 8 mm transducer system components⁴. This includes the 3300 5 mm probe, which is used when an 8 mm probe is too large for the available mounting space^{5,6}.

ProximitoR® Sensor

The 3300 XL ProximitoR® Sensor incorporates numerous improvements over previous designs. Its physical packaging permits high-density DIN-rail installation. It can also be mounted in a traditional panel mount configuration, where it shares an identical "footprint" to older 4-hole mounted ProximitoR® Sensor designs. The mounting base for either option provides electrical isolation, eliminating the need for separate isolator plates. The 3300 XL ProximitoR® Sensor is highly immune to radio frequency interference, allowing installation in fiberglass housings without adverse effects from nearby radio frequency signals. Improved RFI/EMI immunity allows the 3300 XL ProximitoR® Sensor to achieve European CE mark approvals without requiring special shielded conduit or metallic housings, resulting in lower installation costs and complexity.

The 3300 XL's SpringLoc terminal strips require no special installation tools and facilitate faster, more robust field wiring connections by eliminating screw-type clamping mechanisms that can loosen.



Proximity Probe and Extension Cable

The 3300 XL probe and extension cable also reflect improvements over previous designs. A patented TipLoc™ molding method provides a more robust bond between the probe tip and the probe body. The probe's cable is more securely attached as well, incorporating a patented CableLoc™ design that provides 330 N (75 lbf) pull strength where the probe cable attaches to the probe tip.

3300 XL 8 mm Probes and Extension Cables can also be ordered with an optional FluidLoc® cable option. This option prevents oil and other liquids from leaking out of the machine through the cable's interior.

Connectors

The 3300 XL probe, extension cable, and Proximator® Sensor have corrosion-resistant, gold-plated ClickLoc™ connectors. These connectors require only finger-tight torque (connectors will "click"), and the specially engineered locking mechanism prevents the connectors from loosening. They do not require any special tools for installation or removal.

3300 XL 8 mm Probes and Extension Cables can also be ordered with connector protectors already installed. Connector protectors can also be supplied separately for installation in the field (such as when the cable must be run through restrictive conduit). Connector protectors are recommended for all installations and provide increased environmental protection⁷.

Extended Temperature Range Applications

An Extended Temperature Range (ETR) Probe and Extension Cable are available for applications where either the probe lead or extension cable may exceed the 177 °C (350 °F) temperature specification. The Extended Temperature Range Probe has an extended temperature rating for up to 260 °C (500 °F) for the probe lead and connector. The probe tip must remain below 177 °C (350 °F). The Extended Temperature Range Extension Cable is also rated for up to 260 °C (500 °F). Both the ETR probe and cable are compatible with standard temperature probes and cables. For example, you can utilize an ETR probe with the 330130 extension cable. The ETR system uses the standard 3300 XL Proximator® Sensor. When using any ETR component as part of your system, the accuracy is limited to the accuracy of the ETR system.

Notes:

1. Proximator® Sensors are supplied by default from the factory calibrated to AISI 4140 steel. Calibration to other target materials is available upon request.
2. Consult Bently Nevada Applications Note, Considerations when using Eddy Current Proximity Probes for Overspeed Protection Applications, when considering this transducer

system for tachometer or overspeed measurements.

3. 3300 XL 8 mm components are both electrically and physically interchangeable with non-XL 3300 5 and 8 mm components. Although the packaging of the 3300 XL Proximator® Sensor differs from its predecessor, it is designed to fit in the same 4-hole mounting pattern when used with the 4-hole mounting base, and will fit within the same mounting space specifications (when minimum permissible cable bend radius is observed).
4. When XL and non-XL 3300-series 5 and 8 mm system components are mixed, system performance is limited to the specifications for the non-XL 3300 5 and 8 mm Transducer System.
5. The 3300-series 5 mm probe (refer to Specifications and Ordering Information p/n 141605-01) uses smaller physical packaging, but does not permit reduced sideview clearances or tip-to-tip spacing requirements compared to an 8 mm probe. It is used when physical (not electrical) constraints preclude the use of an 8 mm probe. When narrow sideview probes are required, use the 3300 NSv™ Proximity Transducer System (refer to Specifications and Ordering Information p/n 147385-01).
6. 8 mm probes provide a thicker encapsulation of the probe coil in the molded PPS plastic probe tip. This results in a more rugged probe. The larger diameter of the probe body also provides a stronger, more robust case. Bently Nevada recommends the use of 8 mm probes when possible to provide optimal robustness against physical abuse.
7. Silicone tape is also provided with each 3300 XL extension cable and can be used instead of connector protectors. Silicone tape is not recommended in applications where the probe-to-extension cable connection will be exposed to turbine oil.

Specifications

Unless otherwise noted, the following specifications are for a 3300 XL 8 mm Proximator® Sensor, extension cable and 8 mm probe between +18 °C and +27 °C (+64 °F to +80 °F), with a -24 Vdc power supply, a 10 kilo Ω load, an AISI 4140 steel target, and a probe gapped at 1.27 mm (50 mils). Performance characteristics are applicable for systems that consist solely of 3300 XL 8 mm components. The system accuracy and interchangeability specifications do not apply when using a transducer system calibrated to any target other than a Bently Nevada AISI 4140 steel target.

3300 XL Extension Cable

330130-AXXX-BXX-CXX

Note: Make sure that the extension cable length and the probe length, when added together, equal the Proximitor® Sensor total length.

Option Descriptions

A: Cable Length Option

- 0 3 0 3.0 metres (9.8 feet)
- 0 3 5 3.5 metres (11.5 feet)
- 0 4 0 4.0 metres (13.1 feet)
- 0 4 5 4.5 metres (14.8 feet)
- 0 7 0 7.0 metres (22.9 feet)
- 0 7 5 7.5 metres (24.6 feet)
- 0 8 0 8.0 metres (26.2 feet)
- 0 8 5 8.5 metres (27.9 feet)

B: Connector Protector and Cable Option

- 0 0 Standard cable
- 0 1 Armored cable
- 0 2 Standard cable with connector protectors
- 0 3 Armored cable with connector protectors
- 1 0 FluidLoc® cable
- 1 1 Armored FluidLoc® cable
- 1 2 FluidLoc® cable with connector protectors
- 1 3 Armored FluidLoc® cable with connector protectors

C: Agency Approval Option

- 0 0 Not required
- 0 5 Multiple Approvals

3300 XL Extended Temperature Range (ETR) Extension Cable

330190-AXXX-BXX-CXX

Note: Make sure that the extension cable length and the probe length, when added together, equal the Proximitor® Sensor total length.

Option Descriptions

A: Cable Length Option

- 0 3 0 3.0 metres (9.8 feet)
- 0 3 5 3.5 metres (11.5 feet)
- 0 4 0 4.0 metres (13.1 feet)

- 0 4 5 4.5 metres (14.8 feet)
- 0 7 0 7.0 metres (22.9 feet)
- 0 7 5 7.5 metres (24.6 feet)
- 0 8 0 8.0 metres (26.2 feet)
- 0 8 5 8.5 metres (27.9 feet)

B: Cable Option

- 0 0 Standard cable
- 0 1 Armored cable

C: Agency Approval Option

- 0 0 Not required
- 0 5 Multiple Approvals

Accessories

141078-01

Manual

159484

Performance Specification – 3300 XL Proximity Transducer System

162735

Performance Specification – 3300 XL ETR probes and extension cables

02120015

Bulk field wire. 1.0 mm² (18 AWG), 3 conductor, twisted, shielded cable with drain wire. Specify length in feet.

137491-AXX

Aluminum probe clamp bracket²

Option Descriptions

A: Mounting screw option

- 0 1 10-24 UNC-2A mounting screws
- 0 2 M5 x 0.8-6g mounting screws

The aluminum clamp bracket is an unthreaded mounting bracket designed to use with the smooth case probes (330140, 330141, 330197 and 330198). After gapping the probe, tighten the clamp bracket by tightening the screws. The mounting screws have pre-drilled holes for safety wire.

137492-AXX

Aluminum probe threaded mounting bracket

Option Descriptions

A: Thread size

- 0 1 3/8-24
- 0 4 M10 x 1

The aluminum probe threaded mounting bracket is the standard mounting bracket for most 3300 and 3300 XL probe